



G - SERIES

GRINDER PUMPS FOR SEWAGE, INDUSTRIAL & AGRICULTURAL USE



The BJM family of single and three phase Grinders are economical and highly efficient pumps for domestic, agricultural and industrial applications. Especially where high lift and the use of small diameter discharge pipe is preferred. Pumps are available for portable use or for permanent installation.

The heart of a submersible pump is its mechanical seals. BJM incorporates **dual** mechanical seals. Lower seal made of Silicon Carbide against Silicon Carbide, installed in a separate oil-chamber. Upper seals made of Carbon against Ceramic. A lip seal is installed under the oil chamber to give additional protection against dirt and moisture. In addition, a thermal overload breaker protects the motor. All BJM Grinder pumps have a sensor installed in the oil chamber giving early warning against water penetration.

The pumps are designed to grind sewage wastewater solids. It will also grind smaller agricultural or industrial waste, such as vegetable matter, thin pieces of plastic or cloth-like materials.

(PLEASE NOTE: Grinder pumps are not designed to pump Metal, Sand, Gravel or other hard materials).

Cut maintenance costs & time with the BJM Slide Rail

Slide rails make routine pump inspections quick and easy. The system eliminates the need for maintenance personnel to climb down into the wet well or sump. Especially beneficial in deep and narrow applications.



G1500



The Grinding wheel and impeller are made of super-hardened high chromium cast iron (FCD70). They can be easily removed and serviced without taking the pump apart. The wheel is reversible for longer wear.

TYPICAL APPLICATION OF GRINDER PUMP SYSTEM

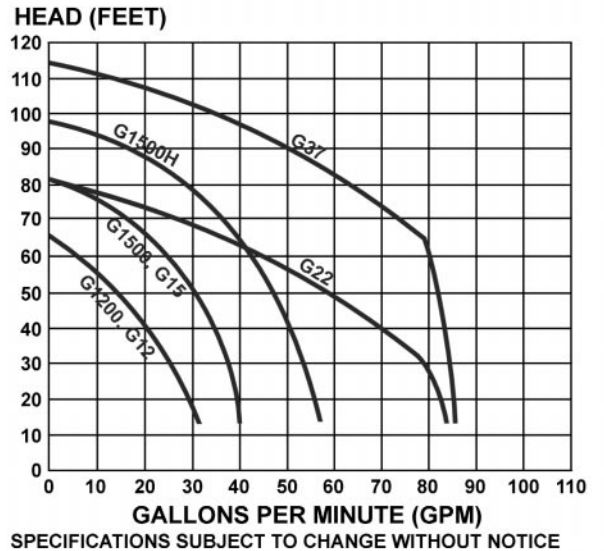
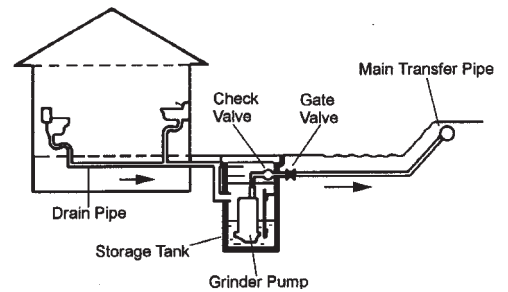

SPECIFICATIONS SUBJECT TO CHANGE WITHOUT NOTICE

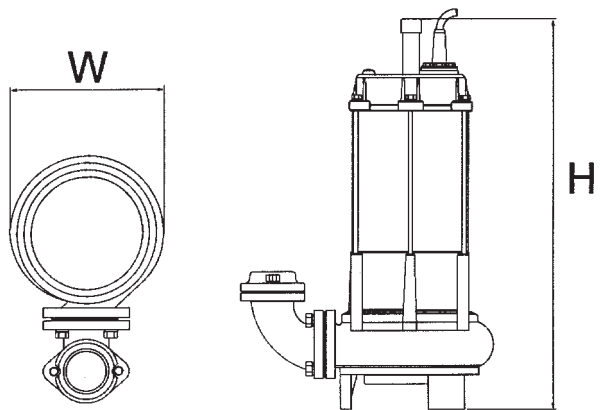

For more information, visit our web site at www.bjmcop.com

Note: Pump Specifications dependent on model and may change without notice.

MODEL	H.P.	VOLT	RPM	RATED AMPS	DISCHARGE SIZE	MAX HEAD	MAX GPM	CABLE	WEIGHT LBS	OVERALL HEIGHT	OVERALL WIDTH
G1200	1.5	230	3600	10	1¼", 1½" or 2"	65'	33	33'	69	18.2"	8.5"
G1500	2	230	3600	14	1¼", 1½" or 2"	82'	38	33'	85	22"	8.5"
G1500H	2.5	230	3600	17	1¼", 1½" or 2"	95'	55	33'	85	22"	7.1"
G12	1.5	230/460	3600	4.6/2.3	1¼", 1½" or 2"	65'	33	33'	69	17.8"	8.5"
G15	2	230/460	3600	6/3	1¼", 1½" or 2"	82'	38	33'	85	19.5"	8.5"
G22	3	230/460	3600	9/4.5	1½" or 2"	82'	85	33'	110	20.5"	10.5"
G37	5	230/460	3600	14/7	1½" or 2"	114'	87	33'	125	22"	10.5"

WARNING: Not for use in flammable liquids.

BJM Corp
 123 Spencer Plains Road
 P.O. Box 1138
 Old Saybrook, CT 06475
 Tel. (860) 399-5937
 (800) 442-BJMC
 Fax. (860) 399-7784
 Web. www.bjmcop.com

Distributor: