



SV-SERIES

NON-CLOG ELECTRICAL SUBMERSIBLE PUMPS FOR SLUDGE, SEWAGE, TRASH & INDUSTRIAL WASTE



THE PERFECT SOLUTION TO GENERAL WASTE-WATER PUMPING

The SV family of pumps from BJM offer long life and trouble free performance at a low investment cost. Motor Casing, impeller shaft and all hardware are made of 304 Stainless Steel, with impeller and other exposed parts made of cast-iron. Each pump is tested at the factory for performance as well as safety.

SUPERIOR MOTOR PROTECTION FOR LONGER LIFE, LESS MAINTENANCE AND LESS DOWN-TIME.

To protect the motor all pumps feature *double* mechanical seals which work in a separate oil chamber. The lower seal is made of Silicon Carbide. *In addition*, an oil-seal ring has been installed under the oil chamber to prevent silt and sand from entering the chamber.

All pumps are equipped with thermal overload protection against over-heating.

Each pump is tested at the factory for performance as well as safety.

Level controls and level control systems are available.

SV Series

The SV-pumps are equipped with Vortex type impellers, undoubtedly the best non-clog impellers ever invented for the handling of mud, raw sewage, viscous liquids, rags, wood chips and other solids. They pass solids up to 90% of pump outlet diameter.

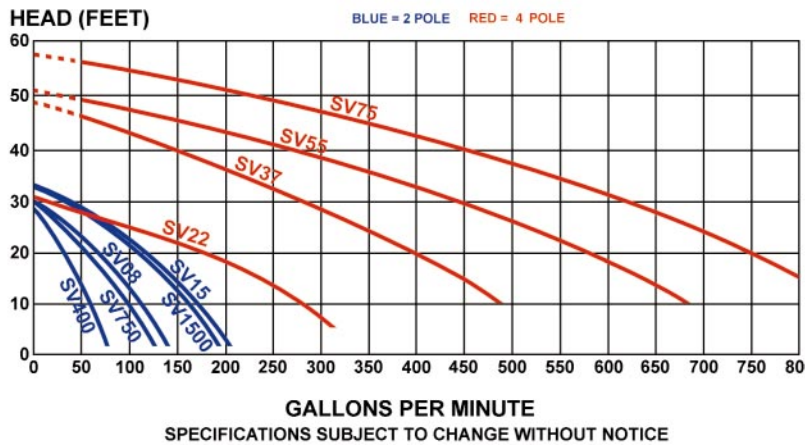
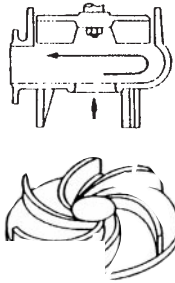

SV400
SV750
SV1500

SLIDE RAIL SYSTEM AVAILABLE FOR ALL SV-SERIES PUMPS

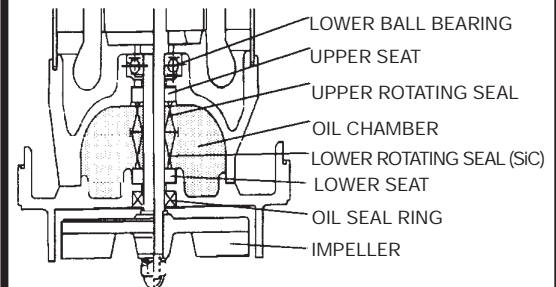
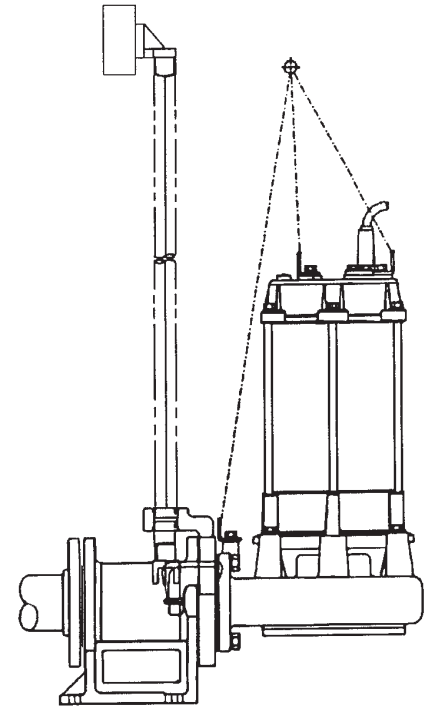

- Triple protection sealing system.
- Double Mechanical Seals in Oil Chamber.
- Oil Seal Ring outside of Oil Chamber.

For more information, visit our web site at www.bjmc.com

MODEL	H.P.	VOLT	RPM	RATED AMPS	DISCHARGE SIZE	MAX SOLIDS	MAX HEAD	MAX GPM	CABLE	WEIGHT LBS	OVERALL HEIGHT	OVERALL WIDTH
SV400	0.5	115 or 230	3600	7.5/3.8	2"	1½"	27'	66	33'	31	15.8"	8.5"
SV750	1	115 or 230	3600	14/7	2 or 3"	1¾"	29'	125	33'	55	20.5"	11"
SV1500	2	230	3600	14	3"	2½"	33'	195	50'	71	24.3"	15.3"
SV08	1	230/460	3600	3/1.5	2 or 3"	1¾"	30'	135	33'	55	18.3"	11"
SV15	2	230/460	3600	6/3	3"	2½"	34'	210	33'	85	21.5"	15.3"
SV22	3	230/460	1750	9/4.5	3"	2¾"	31'	310	33'	145	25.5"	18.3"
SV37	5	230/460	1750	14/7	3"	2¾"	47'	470	33'	160	26.75"	18.3"
SV55	7.5	230/460	1750	19/9.5	4"	3½"	49'	675	33'	246	32.5"	19.7"
SV75	10	230/460	1750	27/13.5	4"	3½"	55'	800	33'	259	32.5"	19.7"

WARNING: Not for use in any flammable liquids.

Specifications subject to change without notice.

123 Spencer Plains Road
P.O. Box 1138
Old Saybrook, CT 06475
Tel. (860) 399-5937
(800) 442-BJMC
Fax. (860) 399-7784
Web. www.bjmc.com

Distributor: